

Archisonic® Cotton

Wall Tiles

938.12.24.000.00

938.13.24.000.00

938.14.24.000.00

Archisonic Cotton Tile

General Information

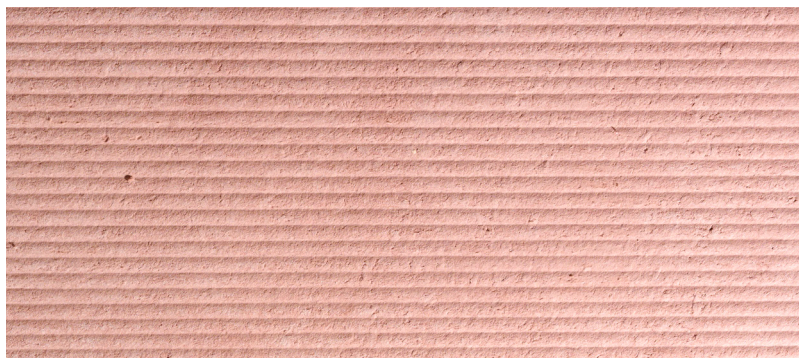

Data

Applicable article numbers

938.12.24.000.00 938.13.24.000.00 938.14.24.000.00

Dimensions¹

Length	600mm	23.6"
Height	300mm	11.8"
Thickness	24mm	0.9"

Material

Wall Covering Archisonic ® Cotton (100% circular) in 24 colors

Weight²

24mm / 0.95" 5.5 kg/m² 1.13 lbs/ft²

Included

Archisonic Cotton
Tiles (28 pieces)



Installation
guide



Take back
program



¹ - all dimensions are nominal ² - all weights are nominal

Archisonic Cotton Tile

Specification Guide

1 Prepare this information:

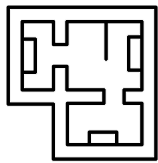

Project Area

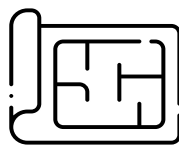

Plans



Other Considerations

2 Specify your Cotton Tile:

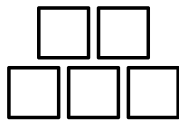

Quantity
(multiple of 28 tiles - 5m²/ 53.8ft²)*



Color
page 9-11

* - Archisonic Cotton Tiles are supplied in a pack of 28 tiles (5m²/ 53.8ft²)

Archisonic Cotton Tile

Product Family Overview

1 Longitude

938.12.24.000.00 - Longitude Pattern Tile

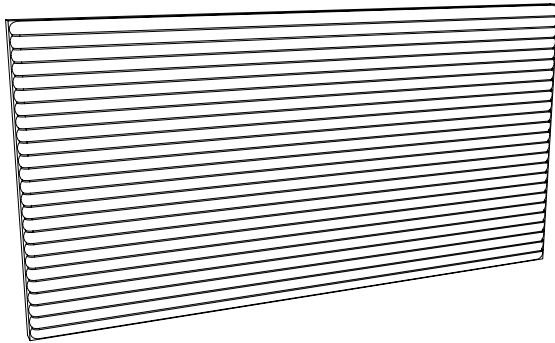

2 Latitude

938.13.24.000.00 - Latitude Pattern Tile

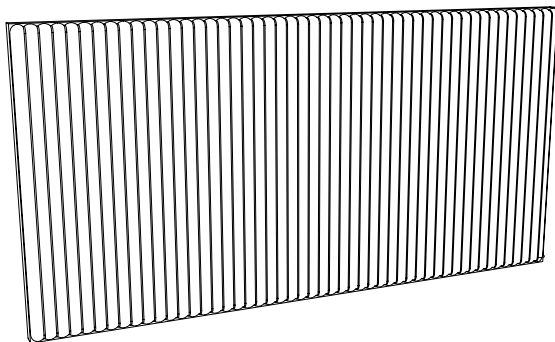

3 Diagonal

938.14.24.000.00 - Diagonal Pattern Tile

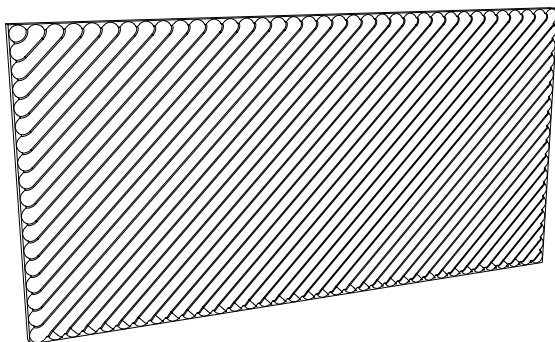

Archisonic Cotton Tile

Geometry Information

Longitude 938.12.24.000.00

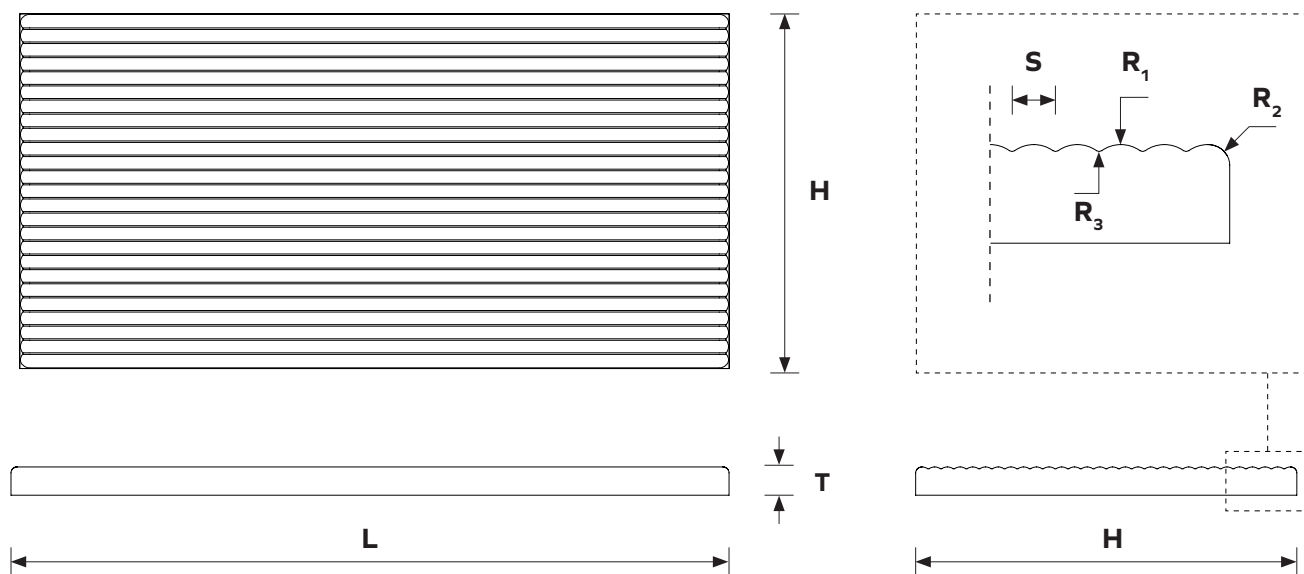

Dimensions table

L	Lenght	600 mm	23.6"
H	Height	300 mm	11.8"
T	Thickness	24 mm	0.9"
S	Spacing	10 mm	0.39"
R₁	Radius	7 mm	0.27"
R₂	Radius	5 mm	0.2"
R₃	Radius	1 mm	0.05"

Archisonic Cotton Tile

Geometry Information

Latitude 938.13.24.000.00

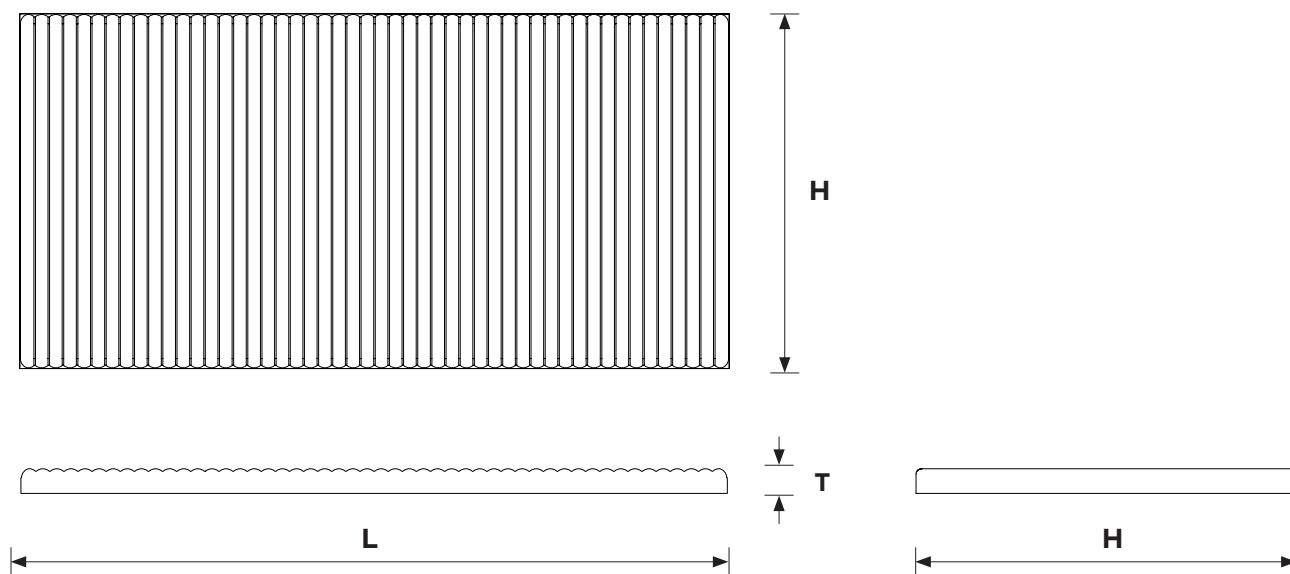

Dimensions table

L	Lenght	600 mm	23.6"
H	Height	300 mm	11.8"
T	Thickness	24 mm	0.9"
S	Spacing	10 mm	0.39"
R₁	Radius	7 mm	0.27"
R₂	Radius	5 mm	0.2"
R₃	Radius	1 mm	0.05"

Archisonic Cotton Tile

Geometry Information

Diagonal 938.14.24.000.00

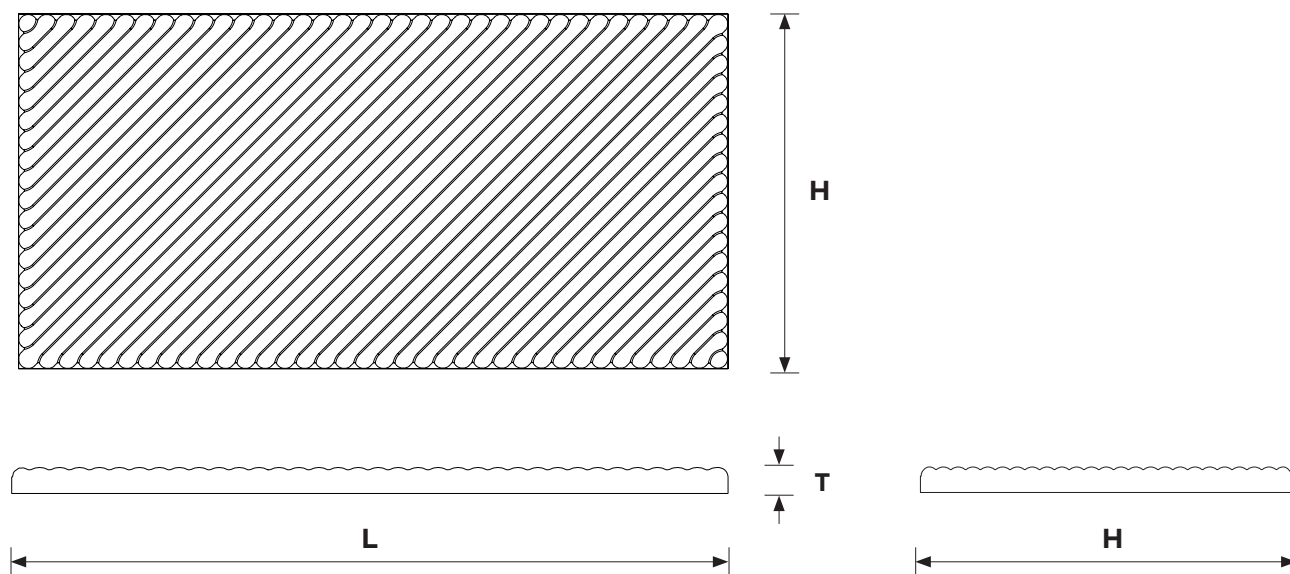

Dimensions table

L	Lenght	600 mm	23.6"
H	Height	300 mm	11.8"
T	Thickness	24 mm	0.9"
S	Spacing	10 mm	0.39"
R₁	Radius	7 mm	0.27"
R₂	Radius	5 mm	0.2"
R₃	Radius	1 mm	0.05"

Archisonic Cotton Tile

Installation Overview

1

Before starting, carefully read the general instructions on page 3 and the guidelines on the use.

2

Draw the fundamental guidelines for the construction of the pattern on the application surface (we recommend always starting from a continuous vertical or horizontal line, when possible).

3

Apply the tiles to the wall, taking care to carefully follow the established pattern (follow the instructions on applying the glue).

Impact Acoustic recommends the use of Pattex No More Nails and assumes no responsibility for non-recommended glues or the use of other fixing systems.

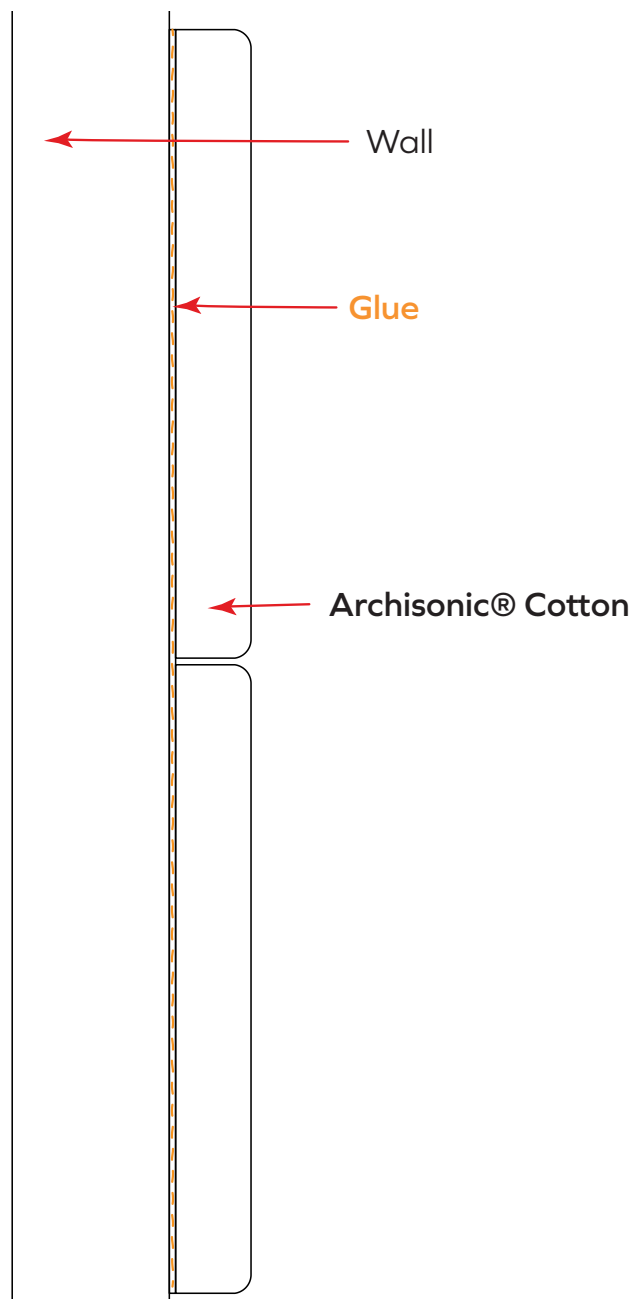

ARCHISONIC®

Colours

Neutrals

24 mm

Neither warm nor cool, this group features three tones of Shadow. Designer White, as the cleanest white available is an essential standalone colour.

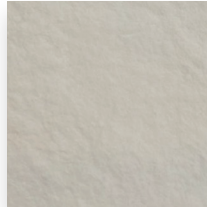

Shadow
20

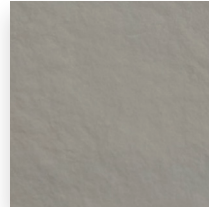

Shadow
30



Shadow
50

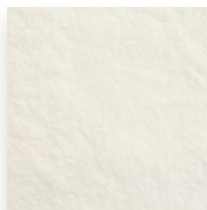

Designer White
00

Warm Neutrals

24 mm

A timeless and classic warm neutral scale represented by three tones of Flax.

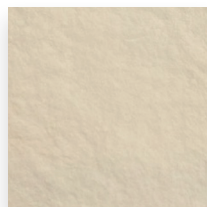

Flax
10

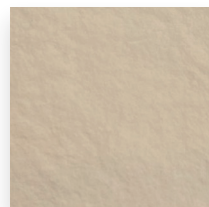

Flax
30

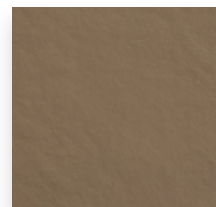

Flax
50

ARCHISONIC®

Colours

Yellows+Oranges

24 mm

A duo tone of Wheat and three tones of Almond create a small group of yellows and oranges.

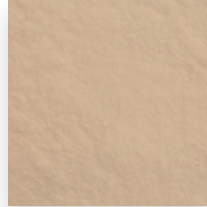

Almond
20

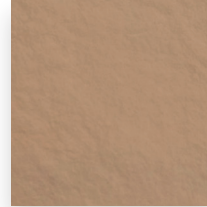

Almond
30

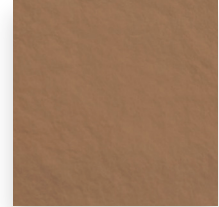

Almond
40

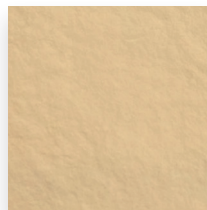

Wheat
30



Wheat
50

Reds+Pinks+ Purples

24 mm

Featuring a duo tone of Rose and a duo tone of the shaded red, Pigeon.

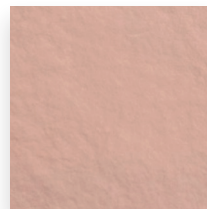

Rose
20



Rose
50

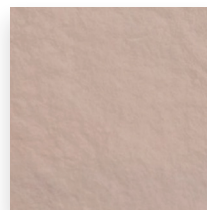

Pigeon
20

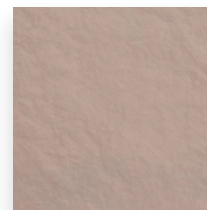

Pigeon
30

ARCHISONIC®

Colours

Blues

24 mm

A classic, easy blue scale represented by three tones of Denim.

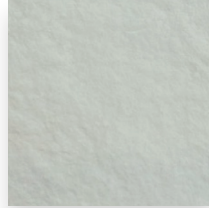

Denim
10

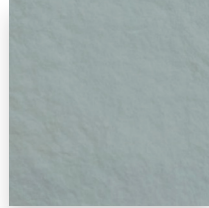

Denim
30

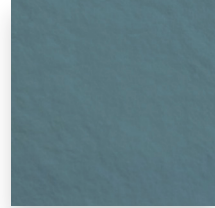

Denim
40

Greens

24 mm

A duo tone of the fresher Aloe and three tones of the more shaded Sage create a commercial group of greens.

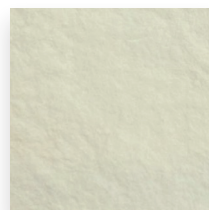

Sage
10

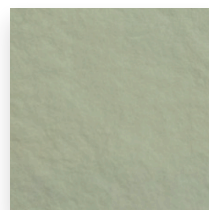

Sage
30

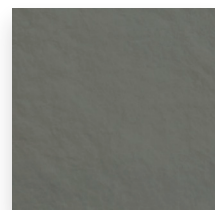

Sage
50

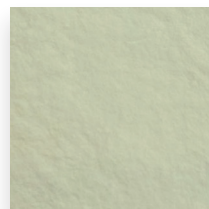

Aloe
30

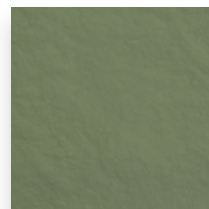

Aloe
50

ARCHISONIC®

Cotton

Density

250kg/m³

15.6lbs/ft³

(+/-10%)



EN 15102: 2007 + A1: 2011
0497

Tile thickness

24mm

0.94"

(+/-10%)

Composition

73% cotton cellulose, 26% mineral components
(micronized kaolin, colouring earths, fireproof salts),
<1% acrylic resin

Fire rating

B-s1, d0

Class 1

EN ISO 13823:2010

(tested with Pattex adhesive)

VOC emission

A+

UNI EN ISO 16000-9: 2006 + ISO 16000-6: 2011

Care instructions

Gently clean with a vacuum cleaner or a dry cloth.

Do not use water, soap or liquid detergents.

Archisonic Cotton Tile

NCS Colour Codes

Developed by Colour Hive

Neutrals	Shadow 20	Shadow 30	Shadow 50	Designer White 00	
NCS Code	S 1500 N	S 4000 N	S 7500 N	S 0300-N	
Warm Neutrals	Flax 10	Flax 30	Flax 50		
NCS Code	S 0603-Y40R	S 3010-Y30R	S 5010-Y30R		
Yellows+Oranges	Almond 20	Almond 30	Almond 40	Wheat 30	Wheat 50
NCS Code	S 0907-Y50R	S 2010-Y50R	S 5020-Y50R	S 0515-Y20R	S 1030-Y20R
Reds+Pinks+Purples	Rose 20	Rose 50	Pigeon 20	Pigeon 30	
NCS Code	S 1020-Y90R	S 2020 Y90R	S 2010-Y90R	S 4010-Y90R	
Blues	Denim 10	Denim 30	Denim 40		
NCS Code	S 0505-B	S 3010-B	S 4020-B		
Greens	Sage 10	Sage 30	Sage 50	Aloe 30	Aloe 50
NCS Code	S 1505-G50Y	S 2005-G50Y	S 6005-G50Y	S 1010 G30Y	S 4020-G30Y

These NCS codes are the closest visual match available and may not be exact to natural pigments.

Circularity

ARCHISONIC® Cotton addresses the issue of sound absorption while being fully circular. Circularity refers to the idea of designing products and processes that are inherently restorative and regenerative. This means that they aim to eliminate waste and pollution while creating a closed-loop system in which resources are used efficiently and sustainably.

ARCHISONIC® Cotton embodies this concept by using only natural and renewable materials in its production process. The main component of the material is cellulose derived from cotton linters, a by-product of the cotton industry that would otherwise be discarded. The production process is also designed to be circular, recycling, and reusing water and minimising waste.

Handcrafted in Italy.

Archisonic Cotton Tile

Acoustic Performance



Testing Standards

ISO 354:2003	Acoustics — Measurement of sound absorption in a reverberation room
ISO 11654:1997	Acoustics — Sound absorbers for use in buildings — Rating of sound absorption
ISO 20189:2018	Acoustics — Screens, furniture and single objects intended for interior use — Rating of sound absorption and sound reduction of elements based on laboratory measurements
ASTM C423-17	Standard Test Method for Sound Absorption and Sound Absorption Coefficients by the Reverberation Room Method
ASTM E795-16	Standard Practices for Mounting Test Specimens During Sound Absorption Tests

Acoustic Test Results

	α_w	SAA	NRC
Archisonic Cotton 24mm	0.60 (H)	0.56	0.55
Archisonic Cotton 24mm with 50mm insulation	0.70 (H)	0.66	0.65

Acoustic Performance

Frequency (Hz)		125	250	500	1000	2000	4000
Archisonic Cotton 24mm	α_{pi}	0.15	0.45	0.55	0.55	0.65	0.75
Archisonic Cotton 24mm with 50mm insulation	α_{pi}	0.55	0.50	0.65	0.70	0.75	0.85

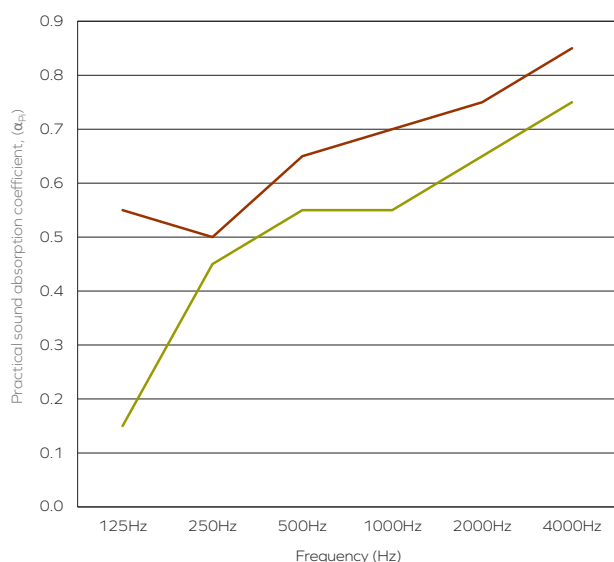

- Archisonic Cotton 24mm
- Archisonic Cotton 24mm with 50mm insulation

The graph represents the practical sound absorption coefficients (α_{pi}) in the third octave band center frequencies. Measurement used Pink Noise as excitation signal in a reverberant room.